



UNI.C.A.



Since 1908

CHIARIFICAZIONE ACQUE

Compatta, di installazione rapidissima e senza fondazioni, l'UNI.C.A. risolve in modo ottimale il problema della chiarificazione delle acque. Il procedimento, statico, a lamelle sovrapposte rende minimo il consumo specifico di flocculante.

WATER CLARIFIER

Compact, very easy to set up without foundations "UNI.C.A." solves in an excellent way the problem of water clarification. The procedure, static, based on overlapped blades, assures a very low specific consumption of flocculant.

CLARIFICATEUR D'EAU

Compacte, d'installation très rapide et sans fondations "UNI.C.A." résout parfaitement le problème de la clarification des eaux. Le procédé, statique, à lamelles superposées réduit considérablement la consommation spécifique de flocculant.

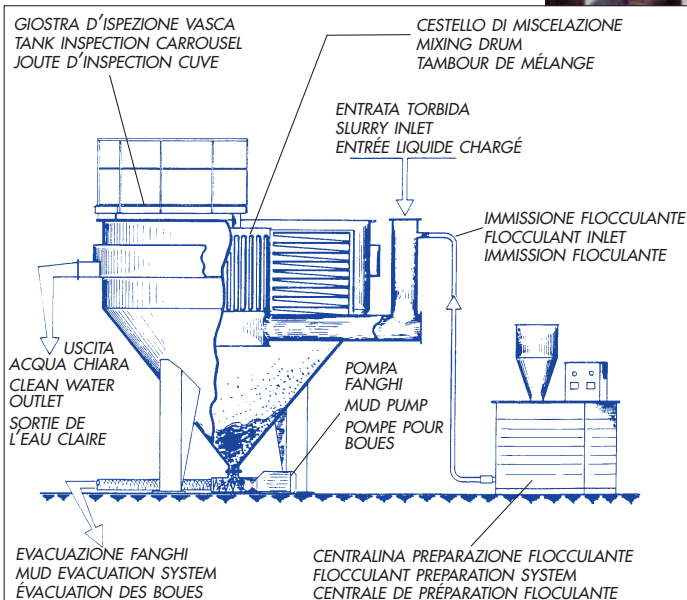

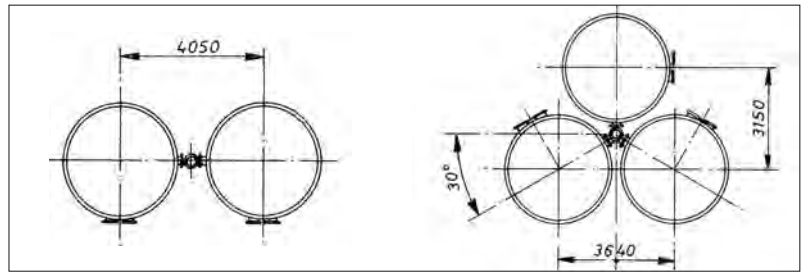
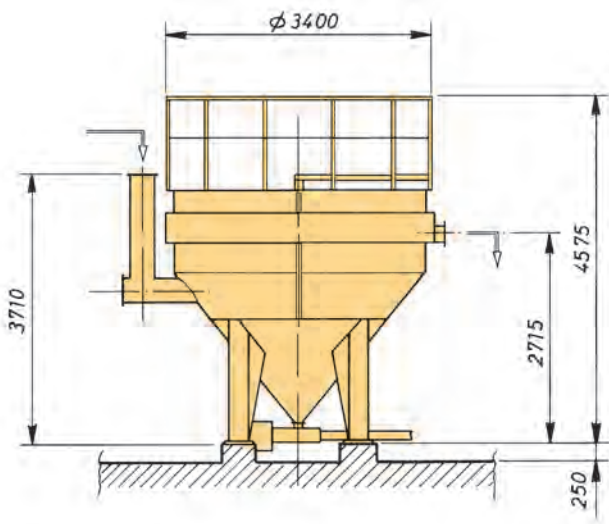

Portata torbida

Slurry capacity [mc/h] 60÷150
Débit liquide chargé

Capacità vasca

Tank capacity [mc] 15
Capacité de la cuve

Perimetro di sfioro

Overflow perimeter [mt] 12
Périmètre de débordement

Peso macchina

Machinery weight [kg] 3.700
Poids de la machine

Potenza installata

Power installed [kw] 5,5
Puissance installée

Consumo polvere polielettrolita (per m³ di torbido)

Polyelectrolyte dust consumption (per each m³ of slurry) [gr] 6 ÷ 12
Consommation de poudre polyélectrolyte (pour m³)



Le caratteristiche e le dimensioni non sono impegnative e la MEM si riserva di apportare modifiche e miglioramenti per ragioni commerciali e tecniche in qualsiasi momento e senza preavviso.

Features and dimensions are not engaging and MEM can make changes and improvements for commercial and technical reasons at any moment and without notice.

Les caractéristiques et dimensions ne sont pas obligantes et la MEM se réserve d'apporter modifications et améliorations pour raisons commerciales et techniques en quelconque moment et sans préavis.

MEM PROGETTA E COSTRUISCE LA PIÙ VASTA GAMMA DI MACCHINE PER LA FRANTUMAZIONE DEGLI INERTI, REALIZZATE IN ITALIA

MEM DESIGNS AND PRODUCES THE WIDEST RANGE OF AGGREGATE CRUSHING MACHINES MADE IN ITALY.

MEM PROGETTA E COSTRUISCE LA PIÙ VASTA GAMMA DI MACCHINE PER LA FRANTUMAZIONE DEGLI INERTI, REALIZZATE IN ITALIA



MEM Società Generale Machine Edili S.p.A.

Direzione e Stabilimento

Via R. Sanzio n° 18/20 - 20090 Segrate (Milano) Italia

Fax: 00 39 02 2136435 - E-mail: info@memitaly.com

Tel.: 00 39 02 2189 521 - www.memitaly.com

PROGETTAZIONE
REALIZZAZIONE
INSTALLAZIONE
ASSISTENZA - RICAMBI

GESTIONE DI:
IMPIANTI DI PRODUZIONE,
IMPIANTI DI TRATTAMENTO
INERTI E RECYCLING